



More Precision





confocalDT // Confocal chromatic sensor system



New products

confocalDT

NEW Confocal high temperature sensors for up to 200 °C
confocalDT IFS2407-xHT/VAC

-  Robust and compact sensor design
-  Submicron resolution
-  High temperature up to 200 °C
-  Suitable for vacuum applications up to UHV
-  For precise distance and thickness measurements

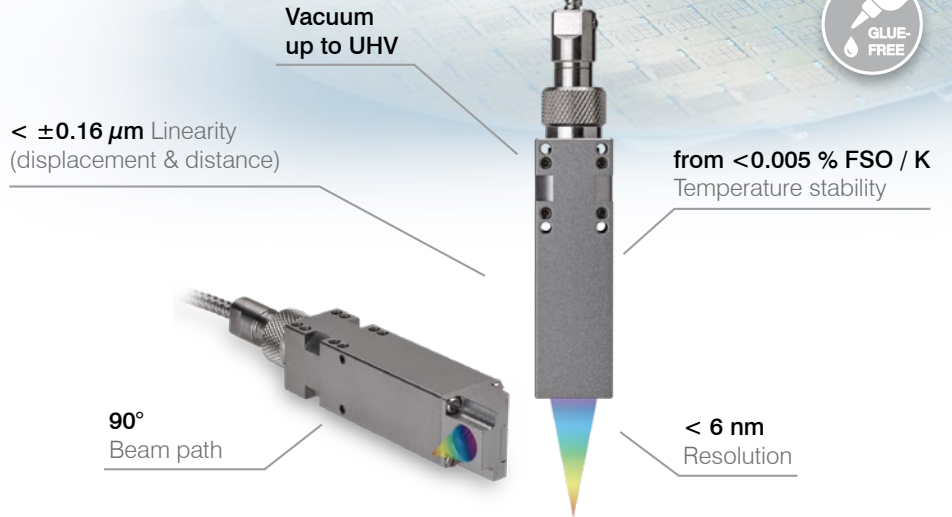

Compact, vacuum-compatible and thermally stable up to 200 °C

The new confocal chromatic sensors set benchmarks for distance and thickness measurements in challenging environments. For the first time, the Micro-Epsilon portfolio includes optical sensors that can withstand temperatures up to 200 °C – with maximum measurement accuracy.

Thanks to their compact design, these sensors are ideal for applications with very limited installation space. The innovative HT models are available in various measuring ranges and with a 90° beam path, and can be flexibly adapted to different installation situations.

By dispensing with organic adhesives, the high-temperature sensors made of stainless steel are low outgassing and therefore ideally suited for use up to ultra-high vacuum (UHV) – the ideal choice for measurement tasks in precision machine building and the semiconductor industry.

Maximum compatibility

All confocalDT sensors are compatible with the IFC controllers. This enables measuring rates up to 30 kHz for fast and reliable process monitoring.

Versatile applications

Versatile designs enable the use in different industries such as the electronics and semiconductor industries, glass industry, medical technology and machine building.

Innovative technology

Their innovative technology enables these sensors to measure reliably even on diffuse and strongly reflective surfaces and under extremely challenging ambient conditions. The passive design of the confocalDT sensors avoids heat radiation into the environment. For vacuum applications, specially developed accessories are available.

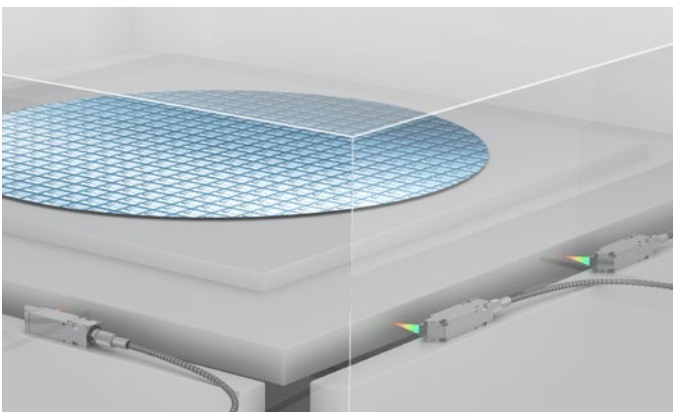





Accurate position detection of wafer tables in vacuum

More details from p. 30.

Confocal high temperature sensors for environments up to 200 °C

confocalDT IFS2407-xHT/VAC

-  Robust and compact sensor design
-  Submicron resolution
-  High temperature up to 200 °C
-  Suitable for vacuum applications up to UHV
-  For precise distance and thickness measurements

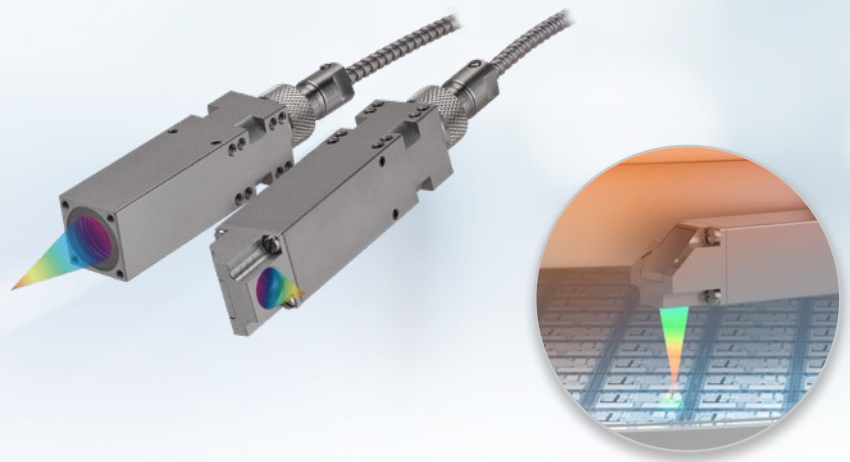

Model	IFS2407-0,8HT/VAC	IFS2407-2HT/VAC	IFS2407/90-2HT/VAC	IFS2407-4HT/VAC	IFS2407/90-4HT/VAC
Measuring range	0.8 mm	2 mm		4 mm	
Start of measuring range	approx. 5.85 mm	14.5 mm	8 mm ^[1]	14.5 mm	8 mm ^[1]
Resolution	Static ^[2]	< 6 nm	< 10 nm	< 24 nm	
	Dynamic ^[3]	< 45 nm	< 90 nm	< 180 nm	
Linearity ^[4]	Displacement and distance	< ±0.16 μm	< ±0.4 μm	< ±0.8 μm	
	Thickness	< ±0.35 μm	< ±0.88 μm	< ±1.76 μm	
Temperature stability ^[5]	<0.015 % FSO / K	<0.005 % FSO / K		<0.01 % FSO / K	
Light spot diameter	11 μm	19 μm		29 μm	
Maximum measuring angle ^[6]	±30°	±12°		±8°	
Numerical aperture (NA)	0.50	0.28		0.19	
Min. target thickness ^[7]	0.04 mm	0.1 mm		0.2 mm	
Target material	reflective, diffuse as well as transparent surfaces (e.g. glass)				
Connection	pluggable optical fiber via FC socket; for cable type and cable length, see accessories				
Mounting	Clamping / screw connection via four mounting holes M2x0.4				
Temperature range	Storage	-20 ... +200 °C			
	Operation	+5 ... +200 °C			
Shock (DIN EN 60068-2-27)	15 g / 6 ms in XY axis, 1000 shocks each				
Vibration (DIN EN 60068-2-6)	2 g/ 20 ... 500 Hz in XY axis, 10 cycles each				
Protection class (DIN EN 60529)	IP40 (vacuum compatible)				
Material	Stainless steel housing, glass lenses				
Weight ^[8]	approx. 40 g	approx. 40 g	approx. 50 g	approx. 40 g	approx. 50 g

^[1] Start of measuring range measured from sensor axis

^[2] Average from 2,048 values at 1 kHz, in the mid of the measuring range onto optical flat

^[3] RMS noise relates to mid of measuring range (1 kHz)

^[4] All data at constant ambient temperature (25±1 °C). Measurement on plane-parallel test glass. Acceptance report is enclosed with delivery

^[5] Depending on the clamping position of the sensor

^[6] Maximum sensor measuring angle up to which a usable signal can be achieved on reflective surfaces, with accuracy decreasing toward the limit values

^[7] Glass sheet with refractive index n = 1.5 throughout the entire measuring range. In the mid of the measuring range, also thinner layers can be measured.

^[8] Sensor weight without optical fiber

Dimensions
(in mm, not to scale)

IFS2407-0,8HT/VAC

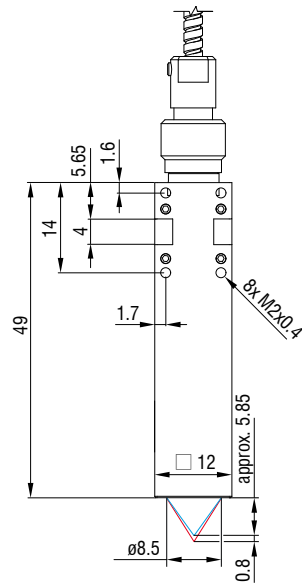

IFS2407-2HT/VAC

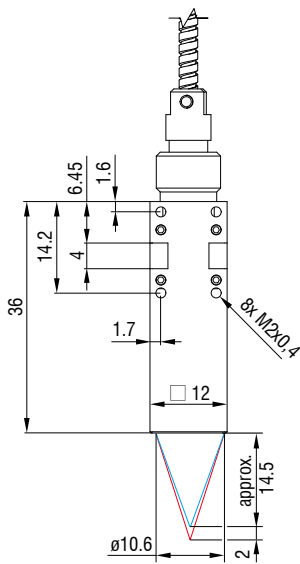

IFS2407/90-2HT/VAC

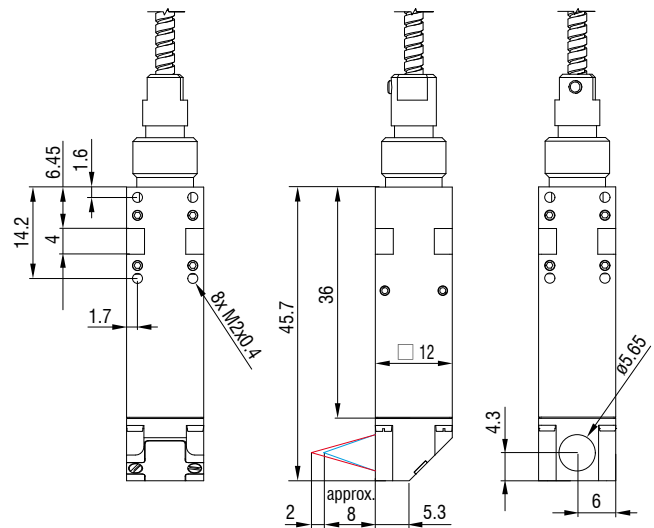

IFS2407-4HT/VAC

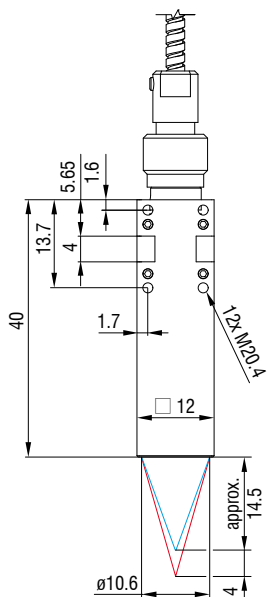

IFS2407/90-4HT/VAC

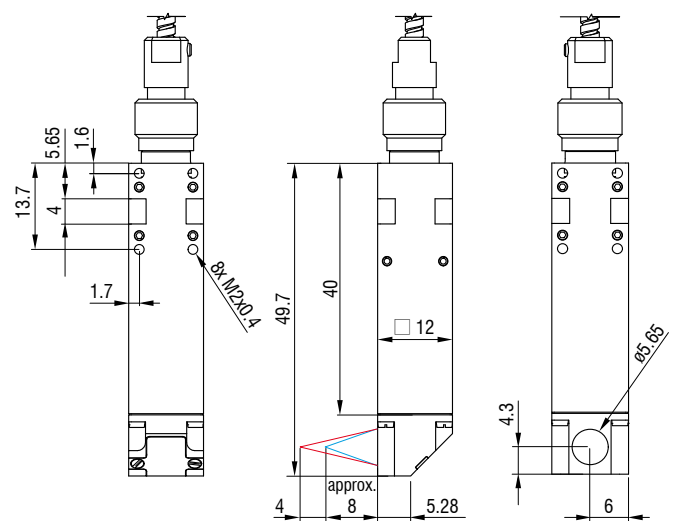

Accessories

Optical fiber and vacuum feedthrough

All Micro-Epsilon confocal controllers are compatible with any IFS240x sensor.

The IFS2402 and IFS2403 sensors already have integrated optical fibers



Standard fiber optics

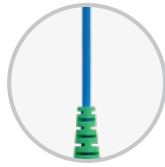

Fiber optics suitable for drag chains



Protective hose for mechanical stress



Robot-compatible fiber optics



Vacuum / UHV version HT version

Sensor-specific optical fiber ¹⁾		IFS2404 Measuring ranges 2/4	IFS2404 Measuring ranges 1/3/6/18	IFS2405	IFS2406	IFS2407	IFS2407-HT
C2404-x	with FC/APC and E2000/APC connectors; fiber core diameter 20 μm (0.3 m, 2 m, 3 m, 5 m, custom lengths up to 50 m)	✓ ²⁾	⊘	⊘	⊘	⊘	⊘
C2401-x	with FC/APC and E2000/APC connectors (3 m, 5 m, 10 m, customer-specific length up to 50 m)						
Other versions:							
C2401/PT3-x	Optical fiber with protective hose for mechanical stress (3 m, 5 m, 10 m, customer-specific length up to 50 m)	⊘	✓	✓	✓	✓	⊘
C2401-x(01)	Optical fiber core diameter 26 μm (3 m, 5 m, 15 m)						
C2401-x(10)	Drag-chain suitable optical fiber (3 m, 5 m, 10 m)						
C2401-x(20)	Robot-suitable optical fiber (3 m, 5 m, 10 m)						
C2400-x	2x FC/APC connectors (3 m, 5 m, 10 m, customer-specific length up to 50 m) ⁵⁾						
Other versions:							
C2400/PT-x	Optical fiber with protective hose for mechanical stress (3 m, 5 m, 10 m, customer-specific length up to 50 m) ⁵⁾	⊘	✓	✓	✓	✓	⊘
C2400/PT-x-Vac	Optical fiber with protective hose suitable for use in vacuum (3 m, 5 m, 10 m, customer-specific length up to 50 m) ⁵⁾						
C2407-x	with DIN plug and E2000/APC (0.3 m, 2 m, 3 m, 5 m)	⊘	⊘	⊘	⊘	✓ ³⁾	⊘
C2404/PT3-x/UHV	Optical fiber with protective hose in a vacuum-compatible design (0.8 m, 1 m, custom lengths up to 50 m) ^{4) 5)}	✓	⊘	⊘	⊘	⊘	✓
C2404/PT3-xHT/UHV	Optical fiber with protective hose, vacuum-compatible design, and rated up to 200 °C (2 m, custom lengths up to 50 m) ^{4) 5)}	⊘	⊘	⊘	⊘	⊘	✓

¹⁾ Bending radius: static 30 mm, dynamic 40 mm

²⁾ The IFS2404-2 and IFS2404/90-2 sensors come standard with a 2-meter cable. For the IFS2404-2(001) and IFS2404/90-2(001) sensors, use the C2401-x(01) cable. It has a standard length of 3 meters.

³⁾ Only IFS2407/90-0,3

⁴⁾ Bending radius: static 60 mm, dynamic 60 mm

⁵⁾ Cannot be plugged directly into the controller. An FC/FC coupler or C2405 + C2401-x vacuum feedthrough is required

Optical fiber extension for sensors

CE2402 cable with 2x E2000/APC connectors

CE2402-x Extension for optical fiber (3 m, 10 m, 13 m, 30 m, 50 m)

CE2402/PT3-x Optical fiber extension with protective hose for mechanical stress (3 m, 10 m, customer-specific length up to 50 m)

Light source accessories

IFL2422/LED Lamp module for IFC2422 and IFC2466

IFL24x1/LED Lamp module for IFC2421 and IFC2465

Accessories

Mounting adapter

Sensor mounting adapter

MA2402 for 2402 sensors

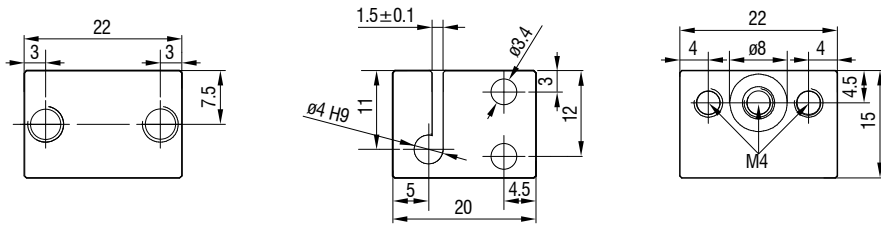

Sensor mounting adapter

MA2403 for IFS2403 sensors

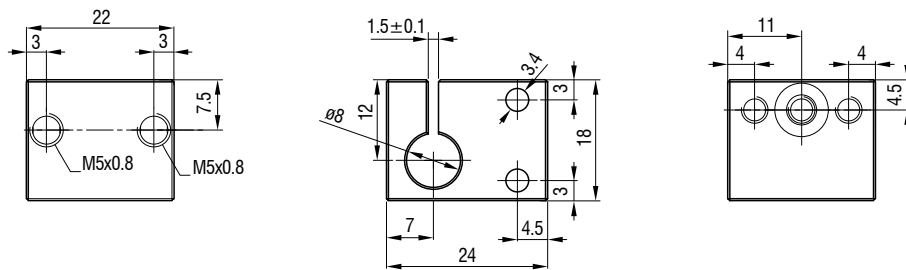

Sensor mounting adapter

MA2404-12 for IFS2404-2 / IFS2404/90-2 / IFS2404-4 / IFS2407-0,1 / IFS2407-0,8 sensors

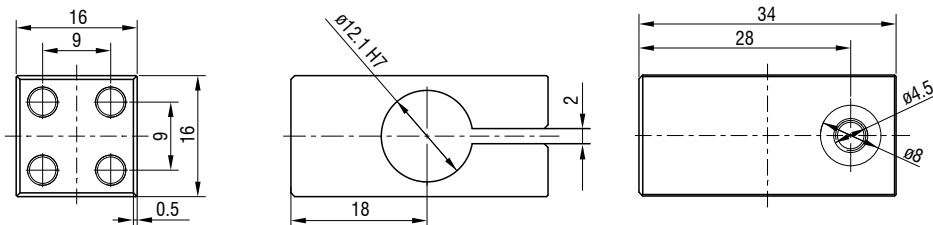

Sensor mounting adapter

MA2400 for IFS2404/IFS2405/IFS2406/IFS2407 sensors (consisting of mounting block and mounting ring)

Mounting block

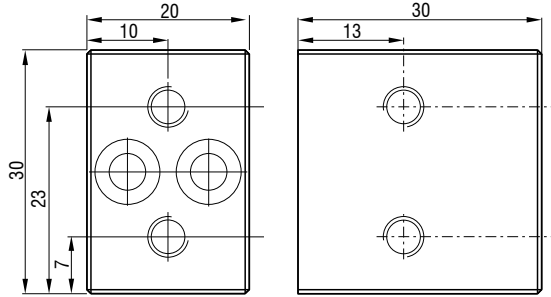

Mounting rings

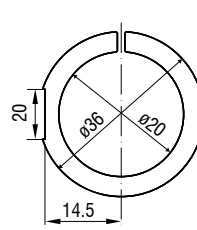

MA 2406-20 for sensors
IFS2406-2,5
IFS2406/90-2.5

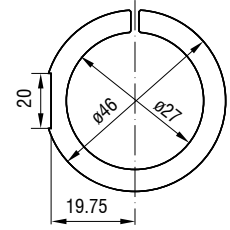

MA 2400-27 for sensors
IFS2404-1 / -3 / -6
IFS2405-0,3 / -1
IFS2406-3 / -10

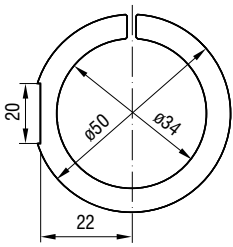

MA 2405-34 for sensors
IFS2405-3
IFS2404-18

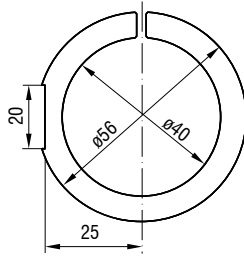

MA 2405-40 for sensor
IFS2405-6

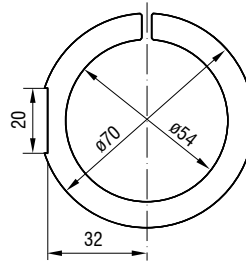

MA 2405-54 for sensors
IFS2405-10
IFS2407-3 / -6

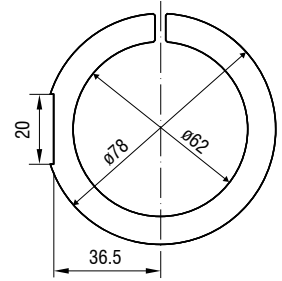

MA 2405-62 for sensors
IFS2405-28 / -30

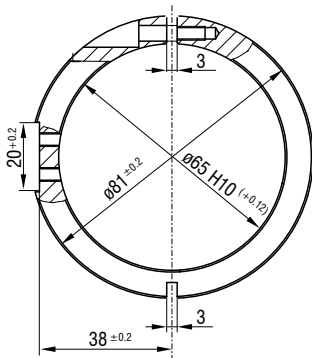

MA 2407-65 for sensor
IFS2407-1,5

Dimensions in mm,
not to scale.



Accessories

Mounting adapter for individual sensors

Manual adjustment mechanism for easy and fast adjustment

Optimal sensor alignment for best possible measurement results

Ideally suitable for machine integration

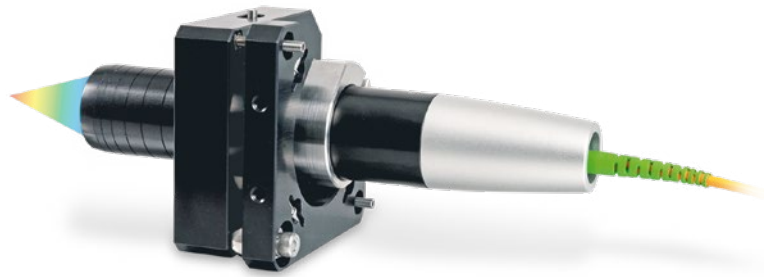

Particularly for high resolution sensors with a small inclination angle, perpendicular installation is required. The JMA-xx mounting adapter enables fine alignment of the sensor to the target via the simple adjustment mechanism. This makes it easy to compensate for minor mounting deviations or tilted measuring objects.

- 1 JMA-xx
- 1 Sensor holder for smaller diameters (not with JMA-27)
- 1 Hexagon screwdriver for positioning
- Setup guide

Scope of supply

Model	JMA-08	JMA-12	JMA-20	JMA-27
Tilting range	X	±4° (continuously adjustable)		
	Y	±4° (continuously adjustable)		
Shifting range	X	±2 mm (continuously adjustable)		
	Y	±2 mm (continuously adjustable)		
Shock (DIN EN 60068-2-27)	15 g / 6 ms on XYZ axis, 1000 shocks each			
Vibration (DIN EN 60068-2-6)	2 g / 20 ... 500 Hz in XYZ axis, 10 cycles each			
Adjustment mechanism	Screw setting mechanism via M3x0.25 screw with hexagon socket 1.5			
Mounting	2x 2 mounting holes for M4x1			
Sensor mounting	Radial clamping for ø 8 mm	Radial clamping for ø 12 mm	Radial clamping for ø 20 mm	Radial clamping for ø 27 mm
Compatibility	confocalDT: IFS2403 series	confocalDT: IFS2404-2 /-4 IFS2407-0,1 /-0,8	confocalDT: IFS2406-2,5/VAC	confocalDT: IFS2404-1 /-3 /-6 IFS2405-0.3 IFS2405-1 IFS2406-3 IFS2406-10

Application examples:

Alignment

Subsequent correction of the mounting position

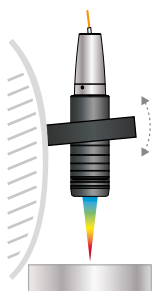

Compensates for incorrect target position

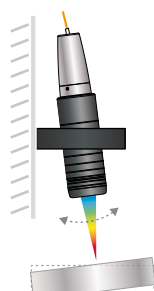

Positioning

Shifting the sensor to target area

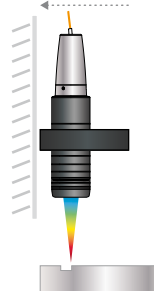

Sensors and Systems from Micro-Epsilon



Sensors and systems for displacement, distance and position



Sensors and measurement devices for non-contact temperature measurement



Measuring and inspection systems for metal strips, plastics and rubber



Optical micrometers and fiber optics, measuring and test amplifiers



Color recognition sensors, LED analyzers and inline color spectrometers

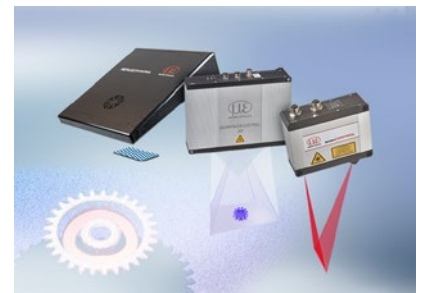

3D measurement technology for dimensional testing and surface inspection