



More Precision

thermoMETER // Non-contact infrared temperature sensors



Non-contact temperature measurement - precise and reliable.



Measuring ranges
-50 to +1100 °C



Highest signal quality



High precision
and speed

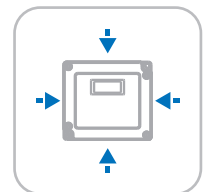

Compact sensors
and controllers

Precise temperature measurement in industrial applications

Infrared pyrometers from Micro-Epsilon are designed for measuring surface temperatures from -50 °C to +1100 °C. The infrared radiation emitted by a body is used for the measurement. As this measurement non-contact, the devices perform wear-free and can therefore be **reliably used over long periods of time**. Selectable models and optical systems enable the installation in different distances from the surface. This allows for the target to be measured from a safe distance in critical applications.

Proven technology for the highest demands

Infrared pyrometers from Micro-Epsilon are extremely compact and characterized by a long service life, robust design and precise measurements. These sensors are based on proven technologies which have been developed further by Micro-Epsilon. This is why these sensors also provide highly precise and reliable measurements in harsh environmental conditions.

Wide range of use in industrial applications

Infrared pyrometers are used in a variety of applications for non-contact temperature measurement: from factory automation, R&D to maintenance, process monitoring and machine building. Their flexibility, combined with high measurement accuracy and durability, makes them the first choice when it comes to non-contact temperature measurement in a wide range of industries.

General information

Page

Next-generation industrial pyrometers

4 - 5

Functional principle & special features





6 - 7

Advantages & fields of use

8 - 9

Infrared pyrometers for industrial series and automation

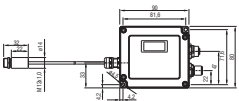
Page

Model		Measuring range	Spectral range	
 thermoMETER UC	High-performance industrial pyrometer	-50 to +1000 °C	8 to 14 μm	10 - 11
 thermoMETER SE	Robust miniature pyrometer	-40 to +1100 °C	8 to 14 μm	12 - 13
 thermoMETER FI	Fully integrated compact pyrometer	-40 to +1100 °C	8 to 14 μm	14 - 15
	Technical drawings			16 - 17
	Connection possibilities and accessories			18 - 19

Next-generation industrial pyrometers

thermoMETER



Compact industrial sensors designed for series applications

For automation, process monitoring and machine building



Parallel digital and analog operation

Sensor configuration does not interrupt the output of measured values



Perfect signal stability and signal quality

Best temperature compensation and EMC immunity on the market



Highest performance in a modern design

Unique combination of high resolution, system accuracy and fast measurement



Perfectly customizable for OEM

e.g. setups/presets, hardware modifications, software features and much more



Various integration possibilities

Via digital and analog outputs, switching outputs or fieldbus connection

Analog

RS485

Ethernet

EtherCAT

EtherNet/IP

PROFI
NET

Powerful pyrometers with a large range of features

Free display and parameterization software is available for the modern infrared temperature sensors from Micro-Epsilon. Measurement data can be displayed, saved and exported in sensorTOOL via USB or RS485 and the sensors can be parameterized for specific applications.

sensorTOOL

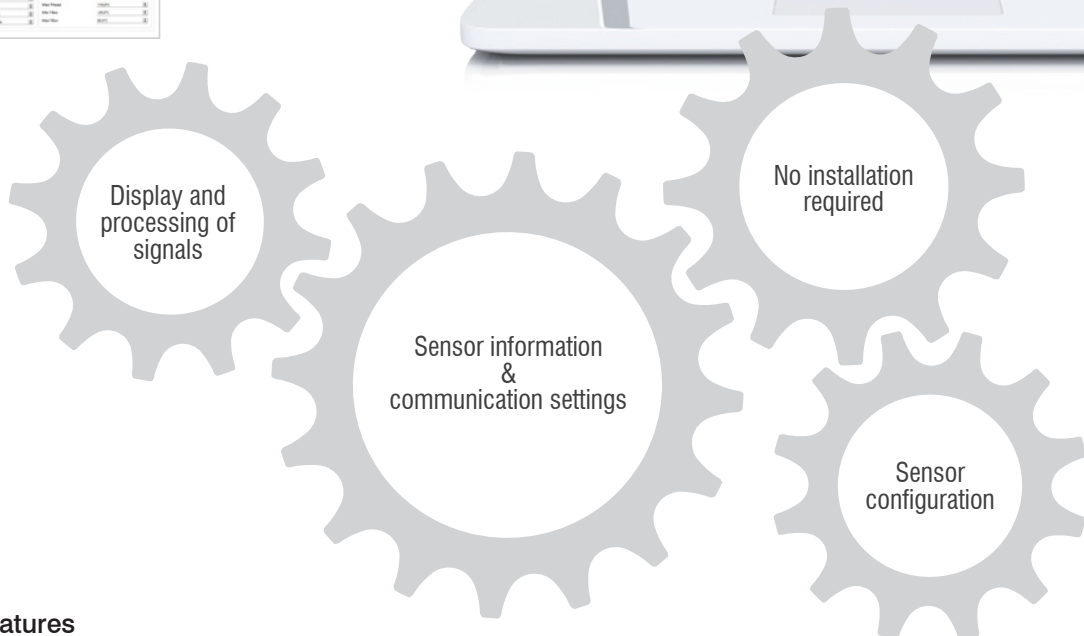

Configuration features

- **Simulation mode:** Testing the cabling for quick commissioning
- **Field calibration:** Setting the offset and gain
- **Alarm function:** For all processing stages of the temperature signal
- **Extensive signal processing functions** such as intelligent averaging, min/max with hysteresis
- **Automatic emissivity calculation**
- **Freely scalable analog output with fail-safe function**

System design and functional principle

thermoMETER

The infrared radiation of a body is used for non-contact temperature measurement. The total amount of radiation detected by the sensor corresponds to 100 % or 1. It is made up of the actual emission of the object, the transmission (e.g. by a heat source behind the measured object) and the reflection (e.g. a heat source is reflected on a metallic surface).

To determine the actual object temperature, only the emission is considered. This is used by entering an emissivity on the pyrometer to calculate the correct temperature of the measuring object.

Emissivity is a material constant that describes the ability of a body to emit infrared energy, taking into account emission or transmission. It can be between 0% and 100%. An ideally radiating body, a so-called "black body", has an emissivity of 1, while the emissivity of a gold mirror, for example, is < 0.1 .

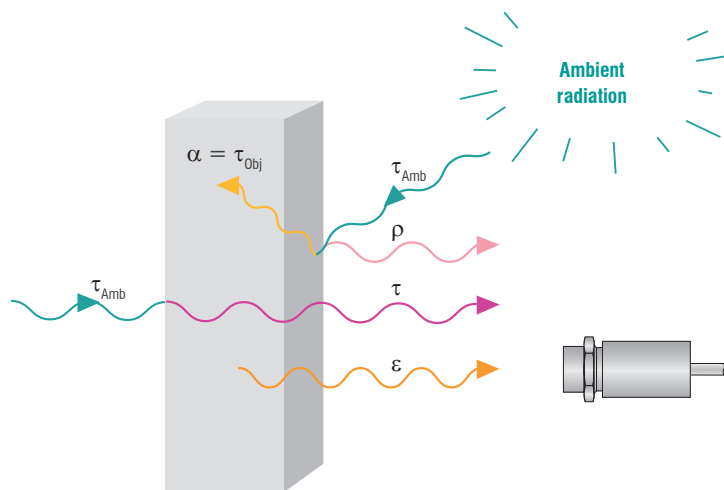

- Absorption (α)**
Radiation absorbed by the object
- Emission (ϵ)**
Radiation emitted by the object
- Reflection (ρ)**
Radiation that is completely or partially reflected by a surface
- Transmission (τ)**
Radiation transmitted by the object

Various system concepts - the right solution for every application

Modern infrared thermometers consist of a lens, a spectral filter, a detector and a controller for signal processing and output. These components can be accommodated in a common housing or designed separately as a sensor and controller.

Micro-Epsilon offers both integrated systems and sensors with remote controllers. Depending on the application, the various advantages of a system variant contribute to the optimum overall solution.

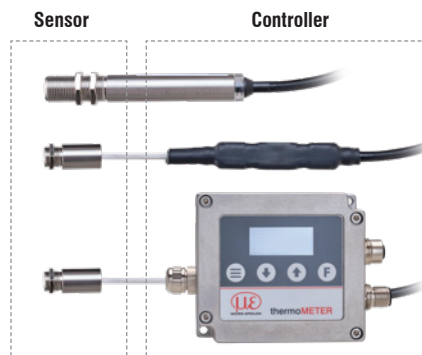

- ✓ Compact all-in-one solution
- ✓ Lower wiring and integration efforts
- ✓ For ambient temperatures up to 80 °C
- ✓ Configuration via programming adapter

- ✓ For high ambient temperatures up to 120 °C surrounding the sensor
- ✓ Lower wiring and integration efforts
- ✓ Analog output can be set to current or voltage
- ✓ Configuration via programming adapter

- ✓ Extended connection and integration possibilities
- ✓ For high ambient temperatures up to 180 °C surrounding the sensor
- ✓ Configuration without PC via buttons & display
- ✓ Two integrated alarm relays
- ✓ Analog output can be set to current or voltage
- ✓ Selection of different lenses

Special features of non-contact infrared temperature measurement

thermoMETER

Emissivity

As can be seen from the functional principle, the emissivity is important for the correct calculation of the temperature value. The emissivity is a fixed factor that theoretically depends on the material, its surface properties, the temperature and the wavelength.

The decisive factor is the highest possible and constant emissivity, which most non-metallic materials have in the long-wave spectral range of 8 - 14 μm

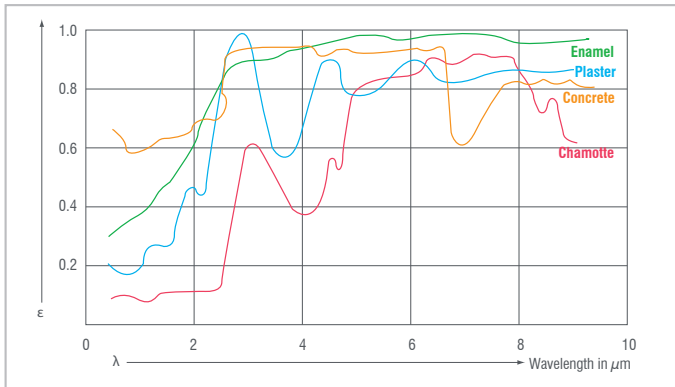

Spectral emissivity of selected substances

- For precise and stable temperature measurements, the emissivity should be as high as possible
- Most non-metallic materials have a high emissivity in the long-wave spectral range

Spot and target sizes

Infrared pyrometers measure the temperature of an object on its surface (spot). The sensor outputs a temperature value averaged over this spot. For reliable measurements, the measuring object should therefore be at least as large as the spot diameter.

The focus point or its size is also influenced by the distance ratio, which defines the optical resolution. It describes how large the measurement spot is at a given distance and is defined as D:S - the ratio of the measurement distance (distance between sensor and measuring object) to the measurement spot diameter.

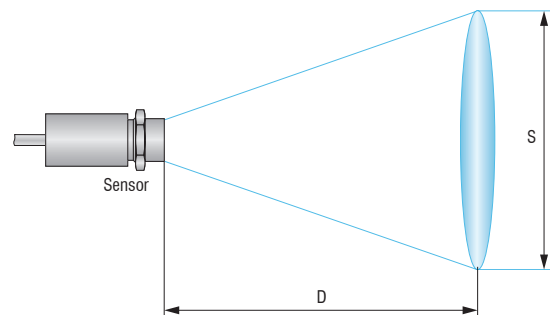
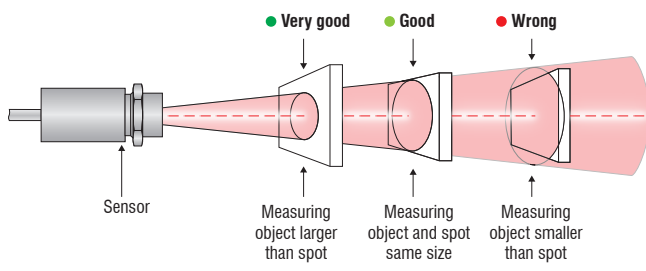

The spot sizes can be changed by selecting the appropriate focus. For example, a CF lens can generate very small spots, while an SF lens generates larger spots, but enables measurements over larger distances.

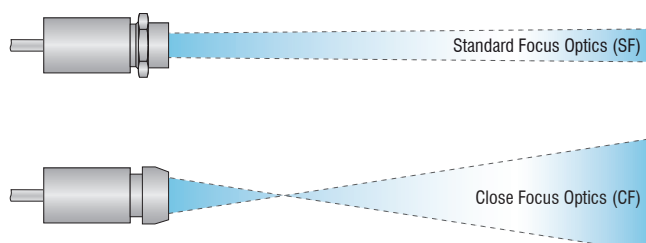

- The optical resolution can be found in the technical data for each model. It improves with higher values.
- The optical tables show the measurement distances and spot sizes to be achieved. The smallest spot diameter is highlighted.

Advantages & applications thermoMETER

Fast measurement

The temperature is measured with very short response times up to 20 ms. The sensors are therefore ideal for monitoring fast inline processes.

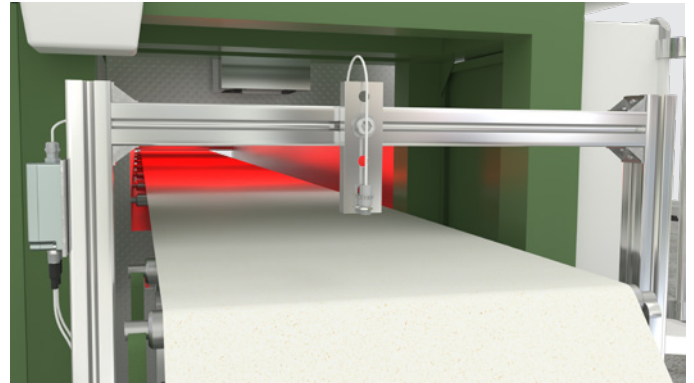

Monitoring the drying process in paper production with thermoMETER UC

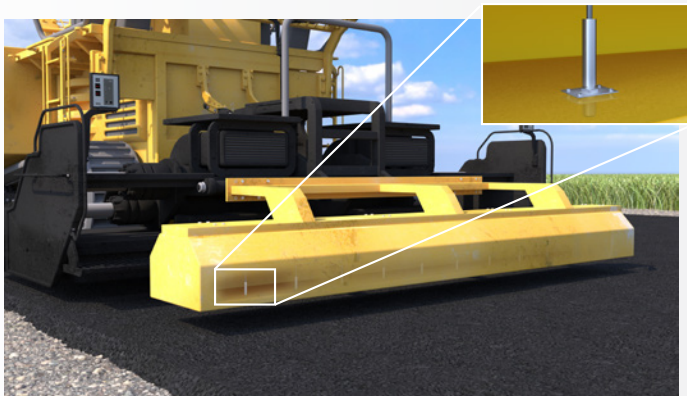

Integrated in asphalt pavers, thermoMETER FI pyrometers measure the asphalt temperature after application

Compact designs ideal for integration

The FI and SE models are among the smallest sensors in their class and are particularly suitable for integration and for OEM applications.

Precise and reliable

Pyrometers from Micro-Epsilon are characterized by maximum measurement accuracy, outstanding signal quality and extremely stable measurement signals. All in all, the new models offer a price-performance ratio that is unique on the market.

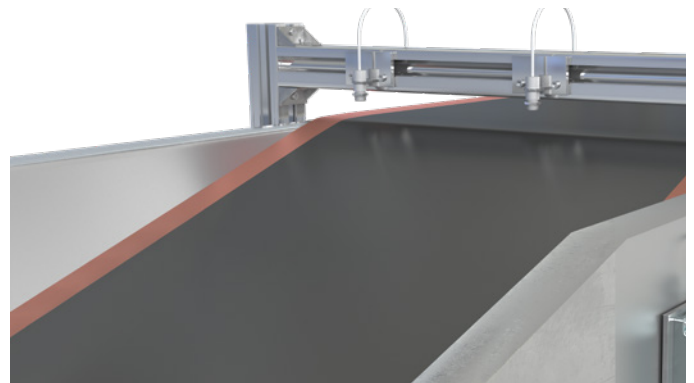

Temperature measurement in the coating process of battery films with thermoMETER UC

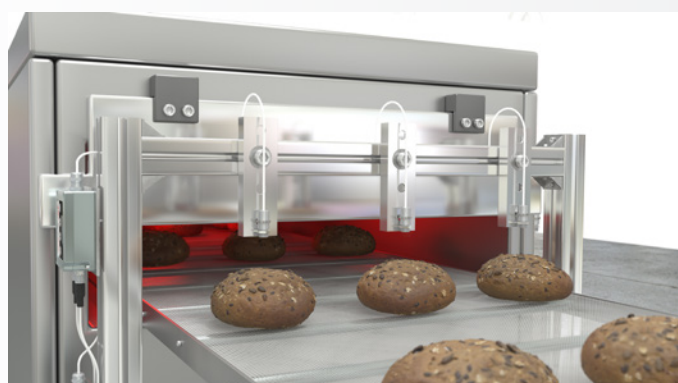

Measuring the temperature of baked goods with thermoMETER UC sensors

Non-contact measurement on moving objects

The main advantage of infrared temperature measurement is that the object being measured is not touched. This enables the measurement of moving objects and does not affect the measured object or its surface.

Large temperature measuring range

Infrared pyrometers have a large temperature measuring range and can therefore be used very flexibly. Depending on the model, temperatures from -50 to +1100 °C can be measured with consistent precision.



Checking the processing temperature when loading asphalt with thermoMETER UC

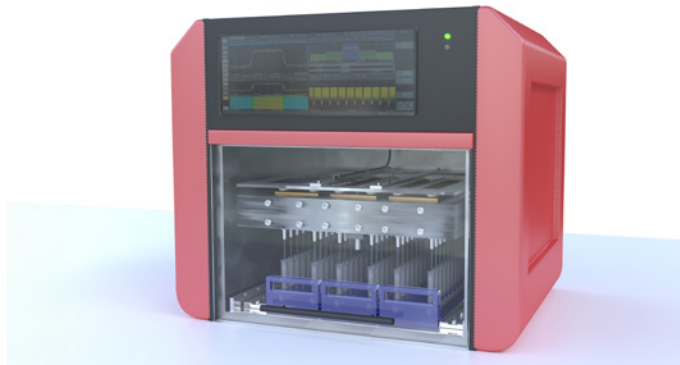

Measuring the temperature of samples in DNA analyzers with thermoMETER FI

Detection of miniature objects

Models with corresponding optics and optional CF attachment lens achieve extremely small spot diameters up to 0.8 mm. This makes precise temperature measurements of even the smallest components possible.

Robust sensor for difficult-to-access places

Micro-Epsilon temperature sensors consist of extremely robust mechanical parts and provide both precise and stable measurement values. Due to excellent temperature compensation, very good EMC immunity and the high IP65 protection class, the sensors are ideally suited for industrial use and also for difficult-to-access places in harsh ambient conditions.

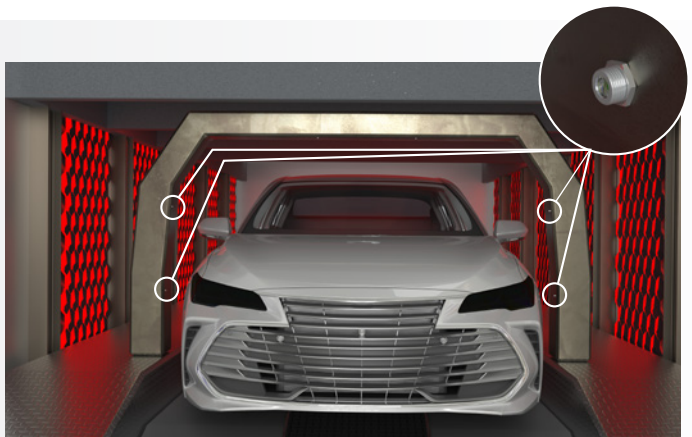

Checking the drying process after painting vehicles with thermoMETER UC

High-performance industrial pyrometer thermoMETER UC

Temperature measuring range
from -50 to +1100 °C

High temperature resolution of 50 mK

Analog and digital interfaces

Powerful alarm relays with 400 mA

No cooling required for ambient
temperatures up to 180 °C

Powerful industrial controller



Versatility and robustness meet highest performance

With the thermoMETER UC, Micro-Epsilon offers an extremely powerful system with a wide range of functions and a modern design. It is used for non-contact temperature measurement of objects in machine building and machine design, in production and for quality assurance.

An extremely compact sensor and an industrial-grade controller in an aluminum die-cast housing with IP65 locally separate measurement and evaluation from each other. The sensor can therefore also be used at high temperatures up to 180 °C; and can be installed in a very space-saving manner. In addition, the thermoMETER UC is particularly suitable when measured values are to be processed digitally, e.g. via industrial interfaces.

Easy configuration via buttons & display

The thermoMETER UC has a powerful industrial controller with an integrated LCD display and four input buttons for quick and easy operation. Optionally, the controller can also be conveniently connected to a PC via an industrial USB cable or RS485 and parameterized using the sensorTOOL software.

Minimum wiring effort

Standard M12 connectors are available for the power supply and signal connection, eliminating the need to open the controller. The sensor is pre-wired firmly and available with different cable lengths.

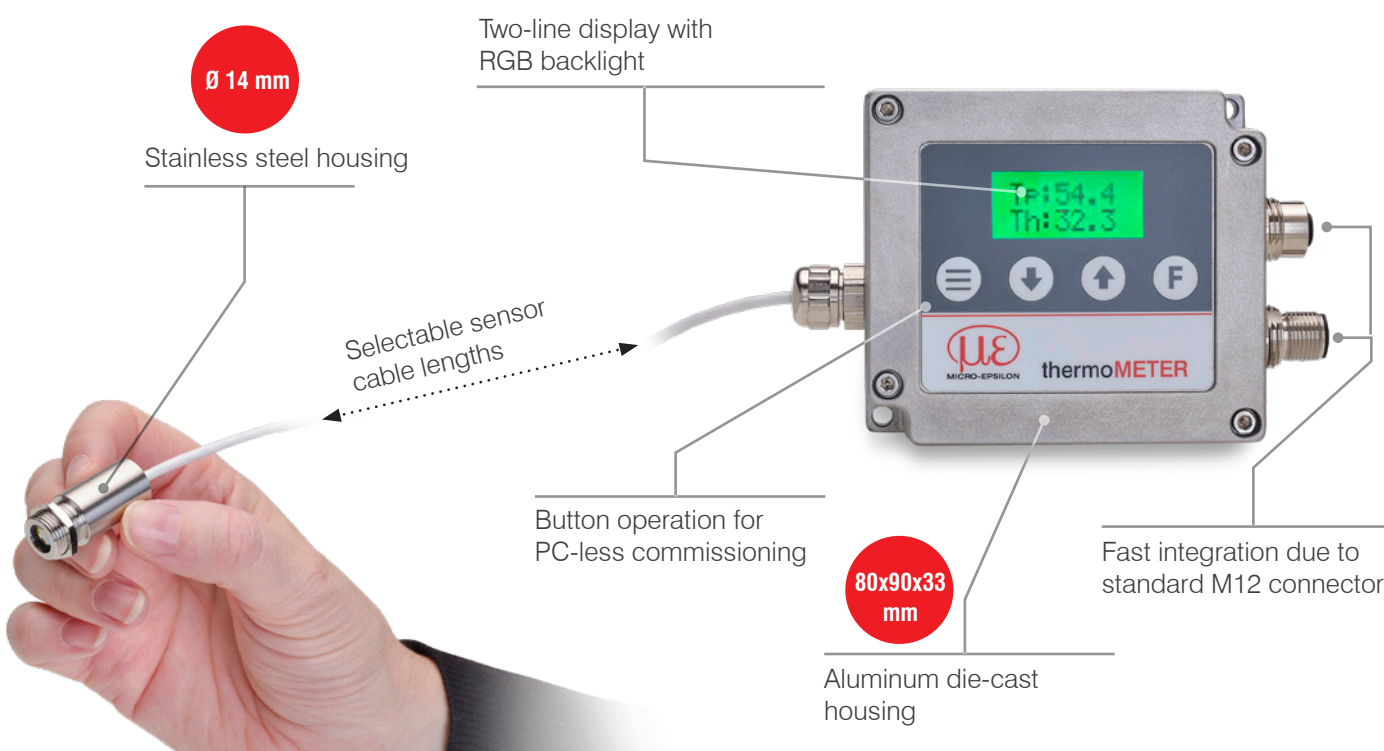

Model		UC-SF02	UC-SF15	UC-SF22
Optical resolution		2:1	15:1	22:1
Measuring range ^[1]		-50 to 600 °C		-50 to 900 °C (1000 °C)
Spectral range		8 to 14 µm		
System accuracy ^[2]		±1.0 % or ±1.0 °C		
Repeatability ^[2]		±0.5 % or ±0.5 °C		
Temperature resolution (NETD) ^[3]		50 mK		
Response time ^[4]		120 ms		
Emissivity		0.100 to 1.100		
Transmittance		0.100 to 1.100		
Signal processing		Intelligent averaging, Min/Max, Hold function with threshold/hysteresis (adjustable via software and buttons)		
Supply voltage		5 ... 36 VDC		
Max. current consumption		< 150 mA		
Digital interface ^[5]		RS485 / USB (3.3V-LVTTTL) / Ethernet / EtherCAT / PROFINET / EtherNet/IP		
Analog output ^[6]		0 (4) ... 20 mA / 0 ... 5 V / 0 ... 10 V (freely scalable within the measuring range)		
Switching output		2x relays for alarm (min/max); 400 mA (short-circuit proof)		
Connection	Sensor	Integrated cable, standard length 3 m, optional 1 m, 8 m or 15 m possible		
	Controller ^[7]	Supply/digital and relay output: 8-pin M12 plug connector (socket) Supply/analog output: 5-pin M12 plug connector (plug)		
Mounting		Sensor Direct fastening via integrated M12x1 thread or fastening using the hexagon nut included in the scope of delivery		
Temperature range	Sensor	Storage	-40 ... 85 °C	
		Operation	-20 ... 120 °C	-20 ... 180 °C
	Controller	Storage	-40 ... 85 °C	
		Operation	-20 ... 80 °C	
Humidity		10 % RH ... 95 % RH (non-condensing)		
Shock (DIN EN 60068-2-27)		50g, 11 ms, each axis		
Vibration (DIN EN 60068-2-6)		3g / 11 ... 200 Hz, each axis		
Protection class (DIN EN 60529)	Sensor	IP65		
	Controller	IP65		
Material	Sensor	Stainless steel (1.4404)		
	Controller	Aluminum die-cast		
Weight	Sensor	approx. 20 g		
	Controller	approx. 280 g		
Control and indicator elements ^[8]		LCD display & membrane keypad for button operation optional operation via sensorTOOL		

^[1] Measuring range can optionally be extended to 1000 °C (only SF22)

^[2] Valid for object temperatures >0 °C and for an ambient temperature of 24 °C ±2 °C; the greater value applies (ε=1)

^[3] With a time constant of 200 ms and an object temperature of 200 °C

^[4] 0 - 90 % energy; adjustable via software

^[5] Connection via an interface module is required for Ethernet, EtherCAT, PROFINET and EtherNet/IP, USB interface only via USB cable (see accessories)

^[6] Depends on supply voltage

^[7] The supply via the optional USB cable (VCC = 5 V) and the supply up to 36 V can be connected at the same time; the higher voltage supply is used in each case. When operating without a USB cable, the power supply up to 36 V can be connected to one of the two M12s.

^[8] Access with sensorTOOL requires USB adapter (see accessories)

Product identification

UC-	SF15-	S3
Cable length: 1m / 3 m (standard) / 8 m / 15 m		
Focus: SF02 / SF15 / SF22		
Series: thermoMETER UC		

Standard Focus (in mm)

		7	53.8	102.5	151.3	200	251.3	302.5	353.8	405		
SF02	2:1	7	53.8	102.5	151.3	200	251.3	302.5	353.8	405		
Distance		0	100	200	300	400	500	600	700	800		
SF15	15:1	7	11.5	14	18	23.5	29.5	35.5				
Distance		0	100	200	300	400	500	600				
SF22	22:1	7	14	12	18.5	23	28	33	36.5	38.5	40	41.5
Distance		0	60	110	210	310	410	510	610	710	810	910

Close Focus (when using the screwable CF lens, in mm)

		6.5	3.9	2.8	2.5	4.8	6.4	8
CF02	2:1	6.5	3.9	2.8	2.5	4.8	6.4	8
Distance		0	10	20	25	30	35	40
CF15	15:1	6.5	3.7	0.8	4.1	5	6.8	8.8
CF22	22:1	6.5	3.4	0.6	4	4.5	6.2	8
Distance		0	5	10	15	20	25	30

 = smallest spot size / focal point (mm)

The ratio D:S (example 2:1, see table) describes the ratio Distance (distance from the front edge of the sensor to the measuring object) to Spot size (measurement spot size).

Robust miniature pyrometer thermoMETER SE

Temperature measuring range
from -40 to 1100 °C

Short response time of 20 ms

Voltage or two-wire current output
(switchable via software)

Open-collector output with 500 mA

No cooling required for ambient
temperatures up to 120 °C

Best price/performance ratio – ideal
for OEM series applications

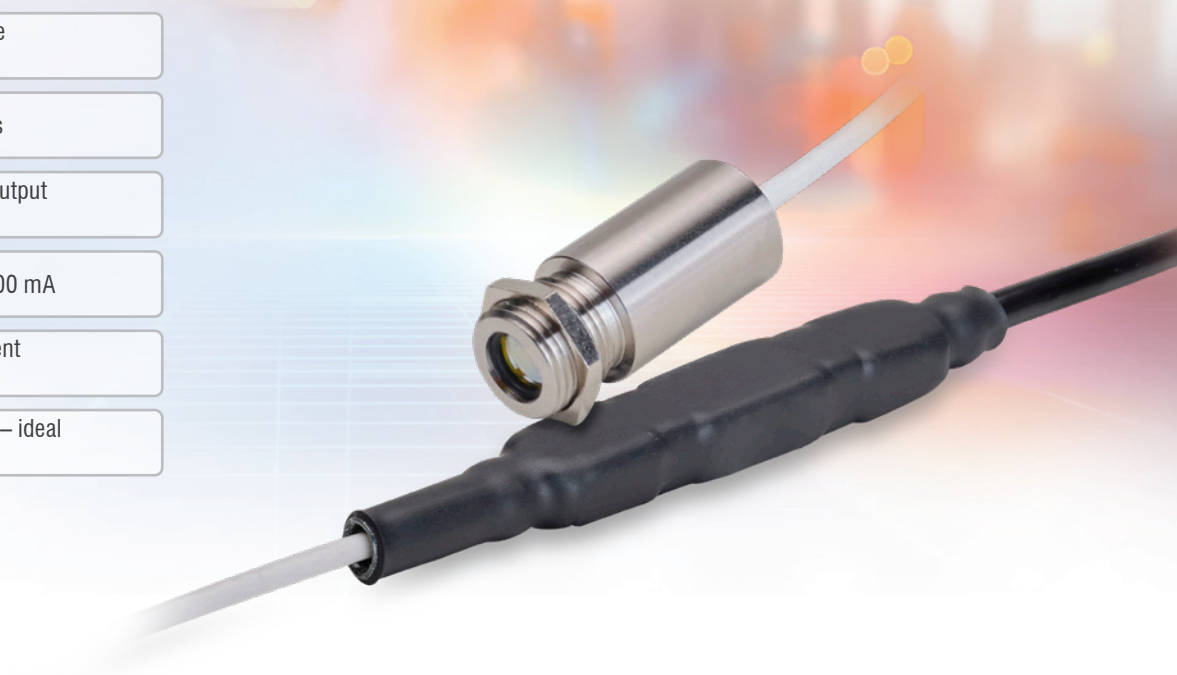

Compact. Robust. Functional.

The thermoMETER SE is a miniature infrared pyrometer for measuring object temperatures up to 1100 °C and is ideal for integration into machines and systems (OEM).

The system combines the advantages of the thermoMETER FI with those of the thermoMETER UC. Since the miniature controller is housed in the cable, the space required is minimized. In addition, the detection point and evaluation are locally decoupled so that the sensor delivers precise measurement values even in environments with high temperatures and under harsh conditions.

Ready-made channel

The sensor, controller and connection cable of the thermoMETER SE are already pre-assembled. The connection is direct and quick via the open cable ends. Optionally, the system can be operated via a USB adapter and set using the sensorTOOL software.



Model		SE-SF15	
Optical resolution		15:1	
Measuring range ^[1]		-40 °C up to 600 °C (1100 °C)	
Spectral range		8 to 14 μm	
System accuracy ^[2]		±1.0 % or ±1.0 °C	
Repeatability ^[2]		±0.5 % or ±0.5 °C	
Temperature resolution (NETD) ^[3]		50 mK	
Response time ^[4]		20 ms	
Emissivity		0.100 to 1.100	
Transmittance		0.100 to 1.100	
Signal processing		Intelligent averaging, Min/Max, Hold function with threshold/hysteresis (adjustable via software)	
Supply voltage		5 ... 30 VDC	
Max. current consumption		≤ 4 mA (voltage output) / ≤ 20 mA (2-wire current output)	
Digital interface		3.3V-LVTTL or USB via programming adapter	
Analog output ^[5]		4 ... 20 mA (two-wire current output) / 0 ... 5 V; 0 ... 10 V (voltage output) freely scalable within the measuring range	
Switching output		Open collector for alarm; 500 mA	
Connection		Integrated cable with open ends (ferrules); standard length 0.5 m sensor and connection cable; optional sensor cable with 3 m, 6 m or 15 m and connection cable with 3 m available	
Mounting		Sensor Direct fastening via integrated M12x1 thread or fastening using the hexagon nut included in the scope of delivery	
Temperature range	Sensor	Storage	-40 ... 85 °C
		Operation	-20 ... 120 °C
	Controller	Storage	-40 ... 85 °C
		Operation	-20 ... 80 °C
Humidity		10 % RH ... 95 % RH (non-condensing)	
Shock (DIN EN 60068-2-27)		50g, 11 ms, each axis	
Vibration (DIN EN 60068-2-6)		3g, 11 to 200 Hz, each axis	
Protection class (DIN EN 60529)	Sensor	IP65	
	Controller	IP65	
Material		Sensor Stainless steel (1.4404)	
Weight		approx. 20 g (sensor only)	
Control and indicator elements ^[6]		Sensor configuration optionally possible via sensorTOOL	

^[1] Measuring range can optionally be extended to 1100 °C

^[2] Valid for object temperatures >0 °C and for an ambient temperature of 24 °C ±2 °C; the greater value applies (ε=1)

^[3] With a time constant of 200 ms and an object temperature of 200 °C

^[4] 0 - 90 % energy; adjustable via software

^[5] Preconfigured for current or voltage on delivery; switchable via sensorTOOL (requires USB converter); voltage scaling depending on the supply voltage

^[6] Access with sensorTOOL requires USB adapter (see accessories)

Product identification

SE-	SF15-	S3-	C3-	U
				Output (preconfigured, switchable via software): U: Voltage 0 ... 5 V / 0 ... 10 V I: Current 4 ... 20 mA
				Cable length (controller - open ends): 0.5 m (standard) / 3 m
				Cable length (sensor - controller): 0.5 m (standard) / 3 m / 6 m / 15 m
				Focus: SF15
Series: thermoMETER SE				

Standard Focus (in mm)

SF15	15:1	6.5	11.5	14	18	23.5	29.5	35.5
Distance		0	100	200	300	400	500	600

Close Focus (when using the screwable CF lens, in mm)

CF15	15:1	6.5	3.7	0.8	4.4	8.1	11.8	15.4
Distance		0	5	10	15	20	25	30

 = smallest spot size / focal point (mm)

The ratio D:S (example 15:1, see table) describes the ratio Distance (distance from the front edge of the sensor to the measuring object) to Spot size (measurement spot size).

Fully integrated compact pyrometer thermoMETER FI

Temperature measuring range
from -40 to 1100 °C

Short response time of 20 ms

Freely scalable voltage output

Open-collector output with 200 mA

No cooling required for ambient
temperatures up to 80 °C

Best price/performance ratio – ideal
for OEM series applications

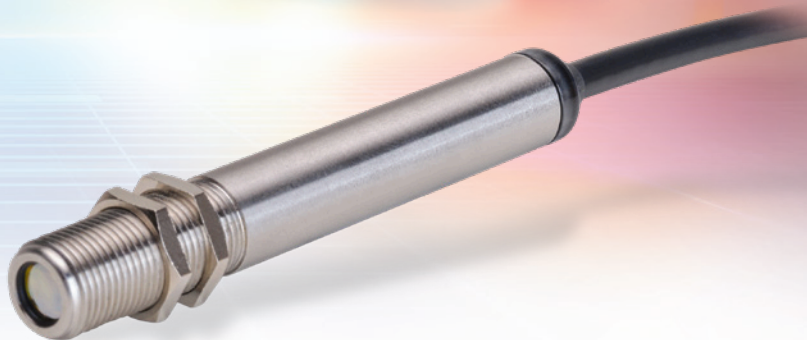

All-in-one pyrometer for OEM and series

The thermoMETER FI is a fully integrated pyrometer for non-contact temperature measurement up to 1100 °C in industrial applications. It is characterized by its extremely compact design, as the sensor and controller are combined in one housing. Its first-class price-performance ratio makes the sensor ideal for series production and OEM use.

Small sensor, great performance

The compact sensor is easy to integrate and ready for immediate use due to preset parameters. Optionally, the sensor can be connected to a PC via USB and individually parameterized. Both extensive signal processing functions and output and alarm settings are available via the sensorTOOL.



Model		FI-SF15
Optical resolution		15:1
Measuring range ^[1]		-40 °C up to 600 °C (1100 °C)
Spectral range		8 to 14 μm
System accuracy ^{[2] [3] [4]}		±1.5 % or ±1.5 °C
Repeatability ^[2]		±0.75 % or ±0.75 °C
Temperature resolution (NETD) ^[5]		50 mK
Response time ^[6]		20 ms
Emissivity		0.100 to 1.100
Transmittance		0.100 to 1.100
Signal processing		Intelligent averaging, Min/Max, Hold function with threshold/hysteresis (adjustable via software)
Supply voltage		5 ... 30 VDC
Max. current consumption		< 6 mA (without LED) / < 20 mA (with LED)
Digital interface		3.3V-LVTTL or USB via programming adapter
Analog output ^[7]		0 ... 5 V / 0 ... 10 V (freely scalable within the measuring range)
Switching output		Open collector for alarm; 200 mA
Connection		Integrated cable with open ends (ferrules); standard length 1 m; optional 3 m, 8 m, 15 m
Mounting		Direct fastening via integrated M12x1 thread or fastening using the hexagon nut included in the scope of delivery
Temperature range	Storage	-40 ... 85 °C
	Operation	-20 ... 80 °C
Humidity		10 % RH ... 95 % RH (non-condensing)
Shock (DIN EN 60068-2-27)		50g, 11 ms, each axis
Vibration (DIN EN 60068-2-6)		3g, 11 to 200 Hz, each axis
Protection class (DIN EN 60529)		IP63
Material		Stainless steel (1.4404)
Weight		approx. 60 g (without cable)
Control and indicator elements ^[8]		Green and red LED (status, alarm and alignment aid) Sensor configuration optionally possible via sensorTOOL

^[1] Measuring range can optionally be extended to 1100 °C

^[2] Valid for object temperatures > 0 °C and at an ambient temperature of 24 °C ±2 °C.

^[3] At 5 VDC; for higher VDC values, ±2 °C or ±2% applies, whichever is greater (ε = 1).

^[4] Valid for object temperatures > ambient temperature; for object temperatures > 200 °C, an additional temperature coefficient of 0.05 K/°C or 0.05 %/°C applies; otherwise 0.15 K/°C or 0.15 %/°C applies; whichever is greater shall apply.

^[5] With a time constant of 200 ms and an object temperature of 200 °C

^[6] 0 - 90 % energy; adjustable via software

^[7] depends on supply voltage

^[8] Access with sensorTOOL requires USB adapter (see accessories)

Product identification

FI-	SF15-	C3
		Cable length: 1 m (standard) / 3 m / 8 m / 15 m
		Focus: SF15
Series: thermoMETER FI		

Standard Focus (in mm)								
SF15	15:1	6.5	11.5	14	18	23.5	29.5	35.5
Distance		0	100	200	300	400	500	600
Close Focus (when using the screwable CF lens, in mm)								
CF15	15:1	6.5	3.7	0.8	4.4	8.1	11.8	15.4
Distance		0	5	10	15	20	25	30

 = smallest spot size / focal point (mm)





The ratio D:S (example 15:1, see table) describes the ratio Distance (distance from the front edge of the sensor to the measuring object) to Spot size (measurement spot size).

Connection possibilities

thermoMETER





Sensor	Cables	Type
thermoMETER FI	Integrated cable Length 1 m / 3 m / 8 m / 15 m	Open ends (with ferrules)



Connection possibilities and accessories	
Connection supply voltage PS2020	
USB programming adapter for connection to PC TM-USBA USB adapter with terminal block	
Interface module for Ethernet and EtherCAT connection IF1032	
Control / machine Analog output (voltage), open collector	









Sensor	Cables	Type
thermoMETER SE	Sensor cable (sensor controller) Lengths 0.5 m / 3 m / 6 m / 15 m Connection cable (Controller - open ends) Lengths 0.5 m / 3 m	Open ends (with ferrules)



Connection possibilities and accessories	
Connection supply voltage PS2020	
USB programming adapter for connection to PC TM-USBA USB adapter with terminal block	
Interface module for Ethernet and EtherCAT connection IF1032	
Control / machine Analog output (current/voltage), open collector	

Sensor	Cables	Type
thermoMETER UC	Digital cable: TM-DC8/x-M12 Lengths 1 m / 5 m	Open ends (with ferrules)
	Digital cable: TM-USBA-M12 Length 1.8 m	USB
	Analog cable: TM-PC5/x-M12 Lengths 1 m / 5 m	Open ends (with ferrules)



Connection possibilities and accessories	
Connection supply voltage PS2020	
USB programming adapter for connection to PC TM-USBA USB adapter with terminal block	
Control / machine 2x alarm relays, RS485	
Interface module for Industrial Ethernet connection IF2035-PROFINET IF2035-EIP IF2035-EtherCAT	
Connection to PC (sensorTOOL) Display & parameter setting	
Interface module for Ethernet and EtherCAT connection IF1032	
Connection supply voltage PS2020	
Control / machine Analog output (current/voltage)	

Mounting accessories / optical accessories / air purge collars

Art. no.	Name		FI	SE	UC
2970750	TM-DIN-UC	Rail mount adapter	⊗	⊗	✓
2970751	TM-MF-UC	Mounting fork	⊗	✓	✓
2970752	TM-APL	Air purge collar, laminar	✓	✓	✓
2970753	TM-FB	Mounting bracket	✓	✓	✓
2970754	TM-AB-UC	Mounting bracket, adjustable in 2 axes	⊗	✓	✓
2970755	TM-MB-UC	Mounting bolt with M12x1 thread and nut	⊗	✓	✓
2970756	TM-TA	Pipe adapter	✓	✓	✓
2970757	TM-T40	Reflection protection tube, length 40 mm; M12x1 external thread	✓	✓	✓
2970758	TM-T88	Reflection protection tube, length 88 mm; M12x1 external thread	✓	✓	✓
2970759	TM-T20	Reflection protection tube, length 20 mm; M12x1 external thread	✓	✓	✓
2970760	TM-MH-UC	Massive housing made from stainless steel	⊗	✓	✓
2970761	TM-FBMH-UC	Mounting bracket for solid housing	⊗	✓	✓
2970762	TM-APMH-UC	Air purge collar made from stainless steel for solid housing	⊗	✓	✓
2970763	TM-CF	Close Focus lens	✓	✓	✓
2970764	TM-PW	Protective window	✓	✓	✓
2970765	TM-AP-UC	Air purge collar (stainless steel) for lenses from D/S 15:1	⊗	⊗	✓
2970766	TM-AP2-UC	Air purge collar (stainless steel) for lenses with D/S 2:1	⊗	⊗	✓
2970767	TM-AP	Air purge collar	✓	✓	✓
2970768	TM-AP8	Air purge collar with 8 mm hose connection	✓	✓	✓
2970769	TM-MI	Right angle mirror	✓	✓	✓

Connection cables for pyrometer UC

2904051	TM-PC5/1-M12	Analog signal and supply cable 1 m
2904052	TM-PC5/5-M12	Analog signal and supply cable 5 m
2904053	TM-USBA-M12	Digital signal cable with USB converter, 1.8 m, M12 plug, USB-A plug
2904054	TM-DC8/1-M12	Digital signal cable, 1 m, M12 plug, ferrules, pre-assembled
2904055	TM-DC8/5-M12	Digital signal cable, 5 m, M12 plug, ferrules, pre-assembled

USB adapter for pyrometers UC / FI / SE

2970770	TM-USBA	USB adapter with terminal block
---------	---------	---------------------------------

IF2035: Interface module for Industrial Ethernet connection

- Connection of RS422 or RS485 interfaces to PROFINET / Ethernet/IP / EtherCAT
- Synchronization output for RS422 sensors
- 2 network connections for different network topologies
- Data rate up to 4 MBaud
- 4-fold oversampling (with EtherCAT)
- Ideal for confined spaces due to a compact housing and DIN rail mounting

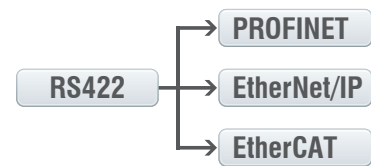

IF1032: Interface module for Ethernet & EtherCAT connection

- Connection of analog output or RS485 to Ethernet and EtherCAT
- Web interface for data display and scaling
- CSV export



Sensors and Systems from Micro-Epsilon



Sensors and systems for displacement, distance and position



Sensors and measurement devices for non-contact temperature measurement

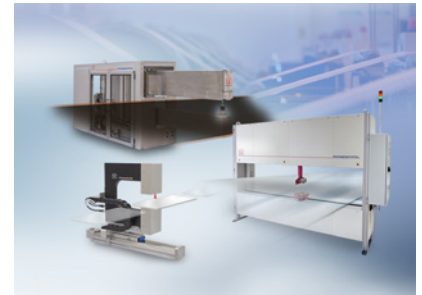

Measuring and inspection systems for metal strips, plastics and rubber



Optical micrometers and fiber optics, measuring and test amplifiers



Color recognition sensors, LED analyzers and inline color spectrometers

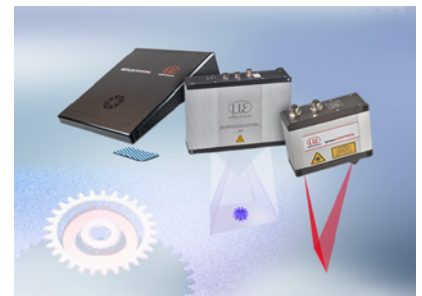

3D measurement technology for dimensional testing and surface inspection